



H2PORTS Project

Introduction and main results

03/12/2025

Jorge M. Lara López
Senior Project Manager and H2ports coordinator
Fundación Valenciaport



FUNDACIÓN
VALENCIAPORT



This project has received funding from the Fuel Cells and Hydrogen 2 Joint Undertaking under grant agreement No 826339. This Joint Undertaking receives support from the European Union's Horizon 2020 research and innovation programme, Hydrogen Europe and Hydrogen Europe research.



AGENDA



H2PORTS FINAL CONFERENCE



08:30 - 09:00 Registration at the headquarters of the Port Authority of Valencia

09:00 - 09:10 Institutional Welcome
Mar Chao, President of the Port Authority of Valencia

09:10 - 09:30 Official Welcome
Antonio Torregrosa, General Director, Fundación Valenciaport
Valerie Bouillon-Delporte, Executive Director, Clean Hydrogen Partnership
Torsten Klimke, Head of Unit – Ports and Inland Navigation - DG MOVE
Juan Manuel Díez, Chief Innovation Officer - Port Authority of Valencia

09:30 - 09:50 H2PORTS project – Introduction and main results
Jorge M. Lara López, Coordinator of H2PORTS project – Fundación Valenciaport

09:50 - 10:15 Hydrogen Refuelling Station and supply operations – Main results
Cristina Ballester, CNH2 Engineer – Centro Nacional del Hidrógeno (CNH2)
Esperanza Montero, Energy Transition – Business Development Manager - Carbueros Metálicos (Air Products Group)



H2PORTS FINAL CONFERENCE



10:15 - 10:40 Hydrogen ReachStacker pilot at MSC Terminal Valencia – Main results
Joost Hoogduin, Vehicle Integration Leader – Hyster-Yale

10:40 - 11:10 Coffee Break

11:10 - 11:35 Hydrogen Yard Tractor pilot at VALTE terminal (by Grimaldi Group) – Main results
Elio Jannelli - CEO Atena scarl - ATENA/University of Naples Parthenope

11:35 - 12:25 Panel Session – H2 demand. Future scenarios and market uptake - Aurelio Lázaro, H2PORTS Technical Coordinator
Carlos Merino, Technical Director - Centro Nacional del Hidrógeno (CNH2)

Héctor Carbonell, H2 and Energy Transition Director Southern Europe - Carbueros Metálicos (Air Products Group)

Cosimo Cervicato, Senior Executive Engineer Energy Saving R&D and Ship Design – Grimaldi Group

Lucien Robroek, President Technology Solutions Division – Hyster-Yale

Viviana Cigolotti, Head of Division Technologies and Vectors for Decarbonization – ATENA/ENEA



H2PORTS FINAL CONFERENCE



12:25 - 12:30 Conclusions and final remarks
Jorge Lara, Coordinator of H2PORTS project

12:30 - 12:35 Family Picture

12:35 - 12:45 Bus Transfer

12:45 - 14:00 Visit to the pilots: HRS / REACHSTACKER / YARD TRACTOR

+ Family Picture

The mobile Hydrogen Refuelling Station - HRS

The Centro Nacional del Hidrógeno (CNH2) has developed the Hydrogen Refuelling Station (HRS) that has guaranteed the supply of this fuel, in suitable conditions, during the simultaneous operation of the other two pilots. Carbueros Metálicos, as an expert in the entire hydrogen value chain, has led the installation of the HRS at the Port of Valencia and has managed it during the pilot period thus guaranteeing good practices of the team involved, and the correct handling of hydrogen loading operations.

1st Hydrogen ReachStacker

The hydrogen ReachStacker is the first-of-a-kind hydrogen powered ReachStacker and was developed by Hyster-Yale. This prototype has been tested in real operations at MSC terminal Valencia.

1st Hydrogen Yard Tractor



AGENDA

H2PORTS FINAL CONFERENCE

Organised by: Hosted at:

The 4x4 Ro-Ro Tractor is the first hydrogen retrofitted powered unit in the world and was developed by ATENA, a research and technology hub based in the Campania Region of Italy. This prototype has been tested in real operations at Valencia Terminal Europa owned by Grimaldi Group.

14:00 - 14:10	Bus Transfer
14:10 - 15:10	Cocktail Lunch
15:10 - 17:30	CLEAN HYDROGEN "H2 in ports" Special Session (Master of ceremony: Mirela Atanasiu, Head of Unit - Clean Hydrogen Partnership)
15:10 - 15:15	Opening session Valerie Bouillon-Delporte, Executive Director, Clean Hydrogen Partnership
15:15 - 16:00	European Strategies and Insights Recent EU strategies for energy (including hydrogen) and ports - Tudor Constantinescu, Principal Adviser to the Director-General for Energy - European Commission Key findings on hydrogen deployment in ports and coastal industrial areas - Stijn Vercammen, Director Climate & Energy - Deloitte Policy-market developments for the port-hydrogen arena - Stanislas Demeestere, Officer, Industry & Sustainability - Hydrogen Europe Role of port ecosystems within Hydrogen Valleys - Lionel Boillot, Project Officer - Clean Hydrogen Partnership

H2PORTS FINAL CONFERENCE

Organised by: Hosted at:

16:00 - 17:00 **Hydrogen in Practice: Port Visions and Realisations**
Presentations from selected European ports (hydrogen strategies, pilot projects, scaling plans)

- Port of Hirtshals (DK), Heidi Tuiskula, Soft Funding Manager - Norwegian Hydrogen AS
- Port of Antwerp-Brugge (BE), Bert de Colvenaer, CEO - WaterstofNet
- Baltic Ports, Jatta JUSSILA, CEO - CLIC Innovation Oy
- Port of Venice (IT), James Orlandi - Head of Project Research & Development Unit and Paolo Menegazzo - Head of Strategic Planning Unit

17:00 - 17:30 **Panel Exchange / Testimonials**
Interactive discussion with representatives from:

- ESPO, Philippe Putman, Senior Policy Advisor Energy, Industry and Decarbonisation
- Zero Emission Shipping Mission Innovation, Layla Chamilothis, Project Coordinator
- CPL - Clean Port & Logistics Cluster, Marie-Kristin Stussnat, Project Employee Hydrogen Applications

17:30 **End of the Final Conference**



Contents

01 Introduction

02 Pilots

03 Project Management

04 Main Results

05 Communication Results

06 Conclusions



01 Introduction

The Port of Valencia

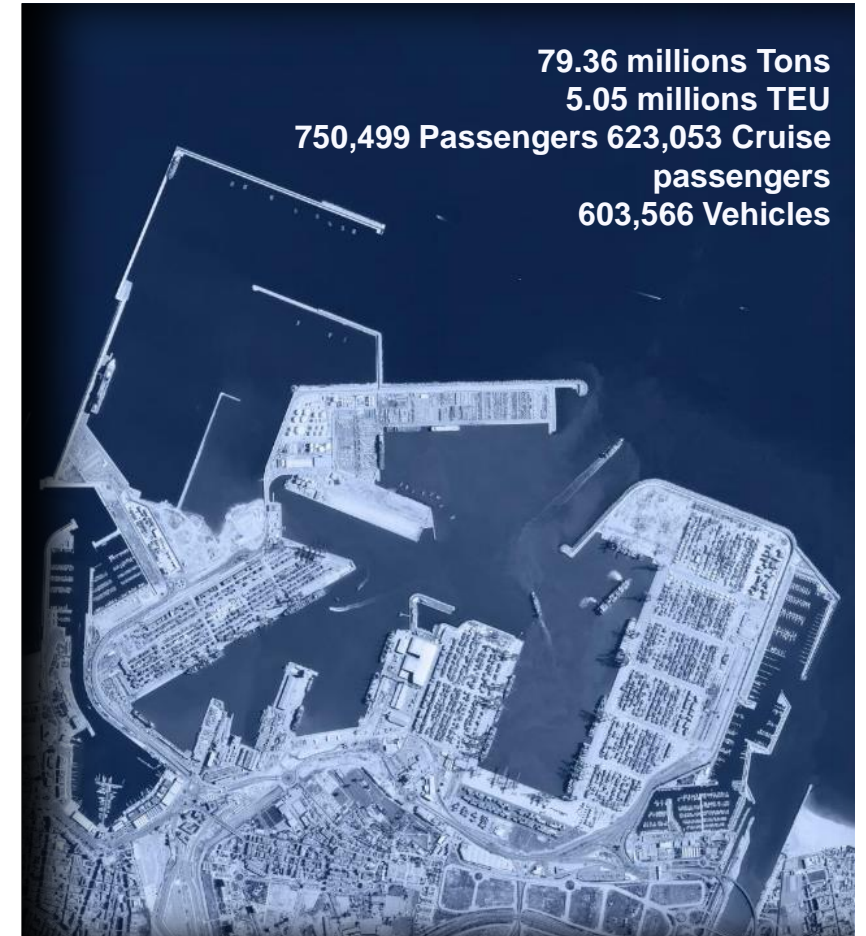



01 Introduction

Implementing Fuel Cells and Hydrogen Technologies in Ports

PORTS

Clean Hydrogen Partnership

Co-funded by the European Union

Port of Valencia

Reach Stacker in MSC Terminal

- 2 years / 5000 h of operation

Mobile HRS

- Hydrogen supply logistics at ports
- Port regulatory framework
- Safety procedures

Yard Tractor in Valencia Terminal Europa

- 2 years / 5000 h of operation

General features

- Total Budget: 4,117,197.5 EUR
- Duration: 2019-2023

First application in Europe of hydrogen technologies for port handling equipment in real operative conditions

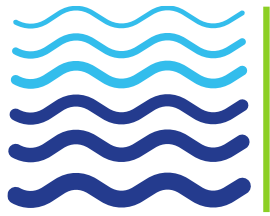

01 Introduction



Coordination:



Public authorities



Research institutions



End users



Industry



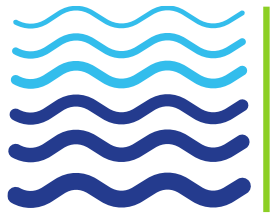

01 Introduction

Timeline

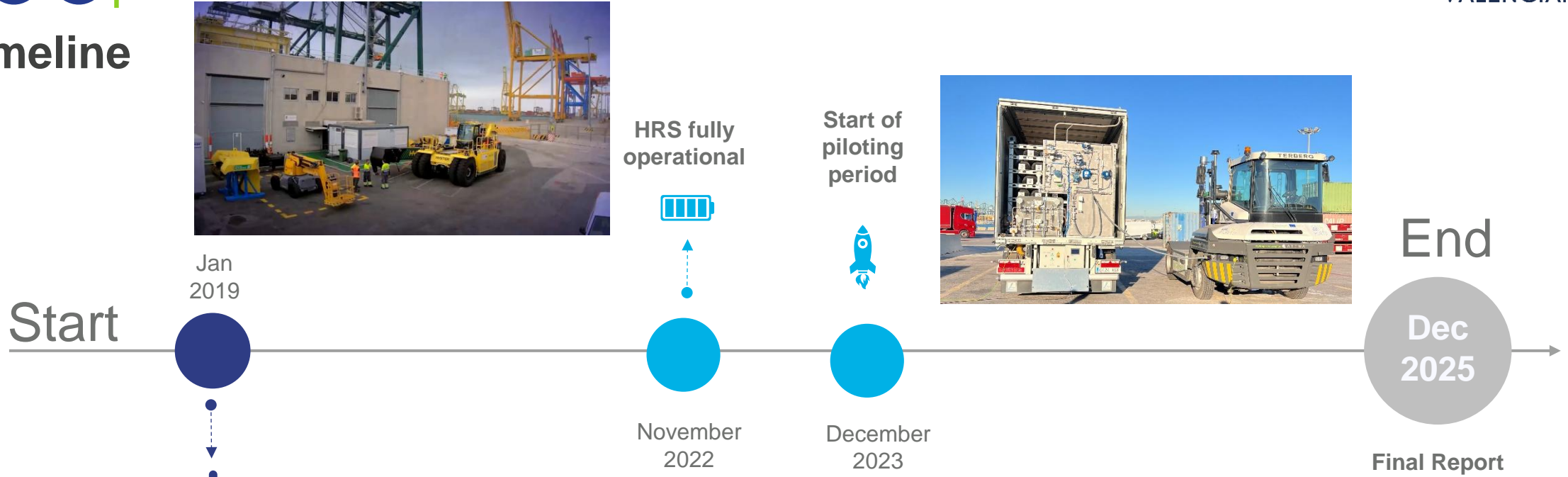

Start of the project

November 2022

December 2023

Final Report





02 Pilots



Gas Supplier



Buffer Tank



Compressor

HYDROGEN SUPPLY



FCHJU funding € 800,000 approx.



National Hydrogen Centre, Carbueros Metálicos, Fundación Valenciaport, Valencia Port Authority, MSCTV, Hyster-Yale, Grimaldi, ATENA, Enagás

Mobile Unit

High pressure storage



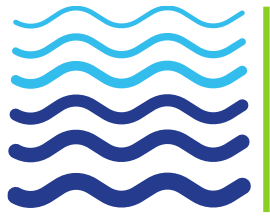

02 Pilots

REACH STACKER



FCHJU funding € 1,300,000 approx.



Hyster-Yale Nederland B.V., MSCTV,
Port Authority of Valencia, Fundación
Valenciaport, National Hydrogen Centre

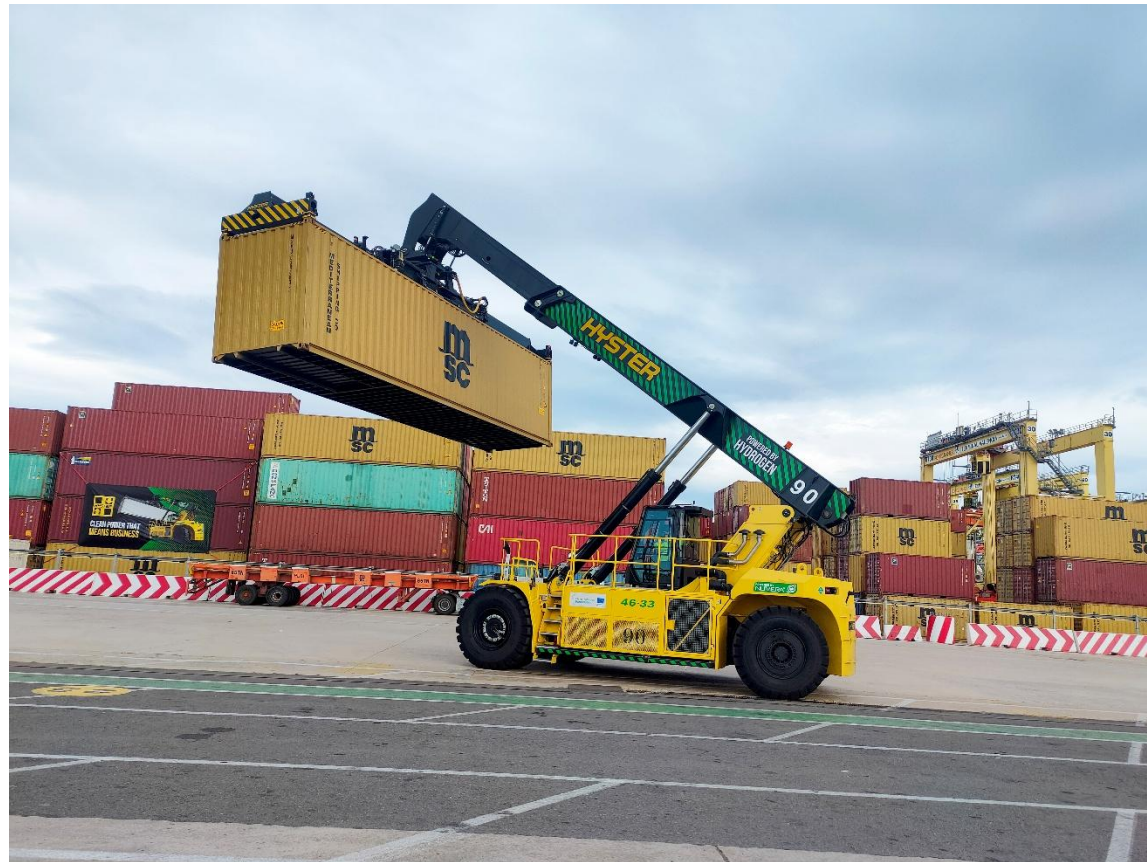

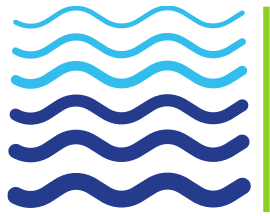

02 Pilots

4x4 YARD TRACTOR



FCHJU funding € 1,100,000 approx.



ATENA, Grimaldi Group, Ballard, National Hydrogen Centre, Fundacion Valenciaport

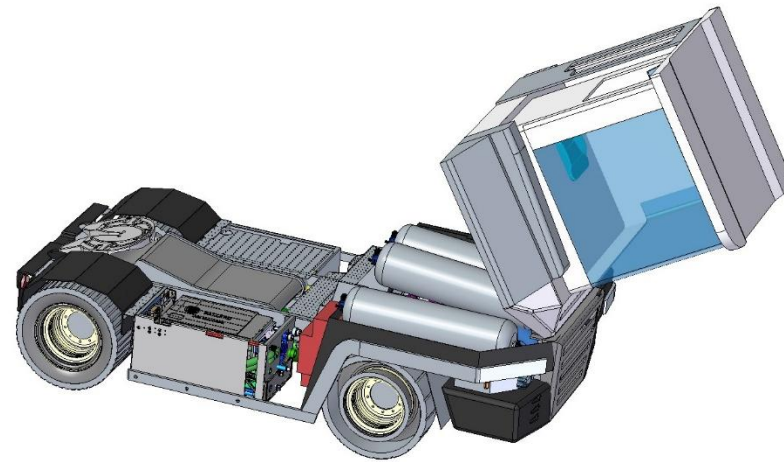
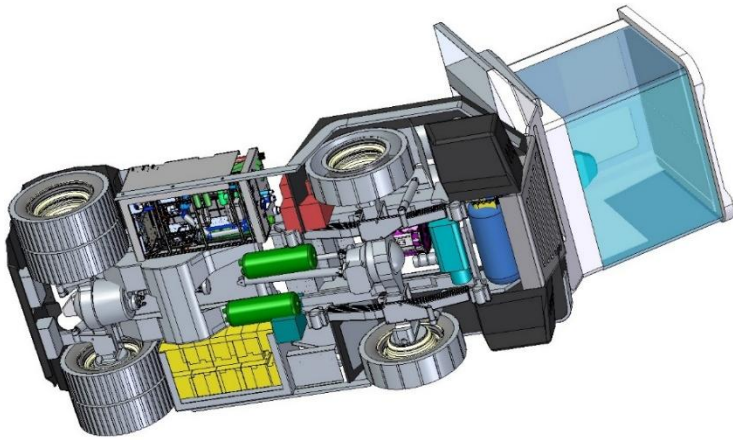

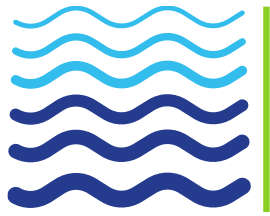

03 Project Management

- **Duration:** 7 years – From 2019 to 2025
- **Harsh reality:** Budget of 4.11 Million € → Expected Budget Consumed ↑ 7 Million €
- **Adaptability and Resilience:** 4 Amendments → COVID impact, H₂ supply expertise by Carbueros Metálicos, crisis of the supply chain, delays in testing final pilots
- **Collaboration:** More than 650 meetings among the consortium, P.O. and with externals and more than 100 people working from the Consortium
- **Guidelines and facts:** More than 30 deliverables produced, papers, procedures, ad-hoc documentation for ports

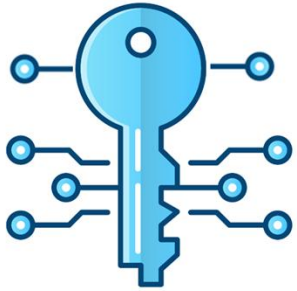

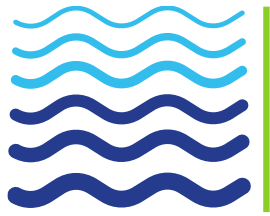

04 Main Results



- Port of Valencia as Innovation Centre for the use of Hydrogen
- First pilots in Europe using green hydrogen. Huge operational experience gained.
- Risk Assessment and Contingency plans of the Port of Valencia
- H₂ Supply procedures for mobility purposes – Coordination of Stakeholders
- Manuals for managing hydrogen at port terminals. Adaptation of terminals and risk assessment
- Approval of the use of hydrogen-powered port machinery on board Ro-Ro vessels
- Stevedores training and port workers involvement

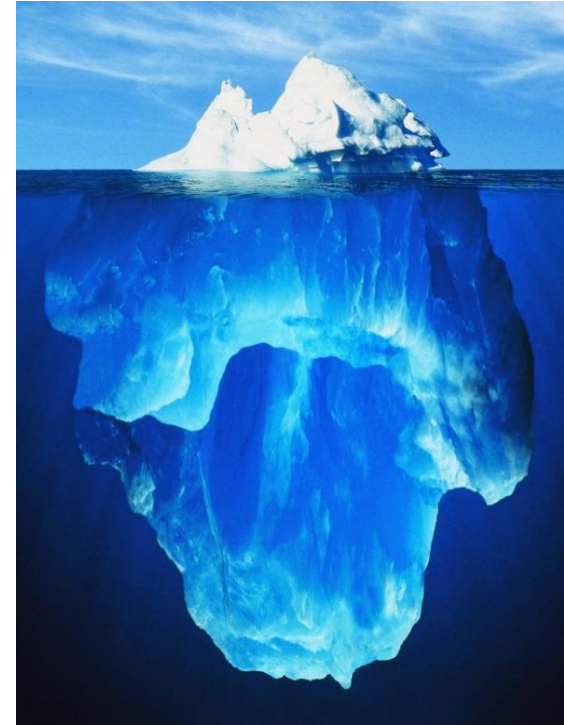



05 Communication Results

STAKEHOLDER ADVISORY GROUP - ↑ 300 PEOPLE



FUNDACIÓN
VALENCIAPORT

PORTS (29)

Puertos de Tenerife
 Motril
 Portos do Madeira
 Venice
 Aveiro
 Bordeaux
 Gothenburg
 Amsterdam
 Açores
 Hamburgo
 Trieste
 Leixoes
 Piraeus
 Livorno
 Cartagena
 Huelva
 Barcelona
 Gijón
 Bilbao
 Bulgarian Ports
 Trois-Rivieres
 Sanguenay
 Vancouver
 Becancour
 NY&NJ
 Port of Kiel
 Port of Sevilla
 City of Yokohama
 Port of Algeciras

INDUSTRY (17)

Calvera
 H2Gas
 Inycom
 Scania
 ESK
 Terberg
 Global Services SRL
 Snam S.P.A.
 Hidrona GEA, S.L.
 Issota fraschini
 Lapesa
 H2B2
 Artelys Brussels
 Seaplace
 Gruppo Sapio
 Naturgy
 H2C SPA

PORT-MARITIME (14)

Baleària
 Boluda
 Bureau Veritas
 DNV GL Spain
 RINA
 Eurogate Hamburg
 SAGGAS
 Terminal Link (Marseille)
 Transbase Soler
 Prácticos Valencia
 FRS Iberia
 HHLA Hamburg
 Yokohama Kawasaki
 International Port Corporation (YKIP)
 DP World Brussels
 Grupo Gimeno

ASSOCIATIONS (7)

ANAVE
 Cluster Energía CV
 FVET
 IVEI
 GASNAM
 LOGISTOP
 EIGA

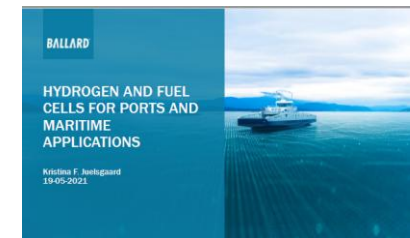
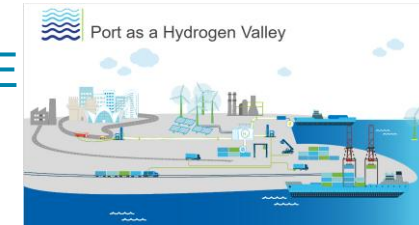

PUBLIC AUTHORITIES (7)

Ajuntament de Valencia
 GVA
 MINCOTUR
 Puertos del Estado
 SASEMAR
 EVE (Ente Vasco Energía)
 MITECO

R&D CENTRES (6)

Joint Research Centre (JRC)
 CMT – UPV
 GCM – UCLM
 University of Genoa
 ITE
 Tecnalia

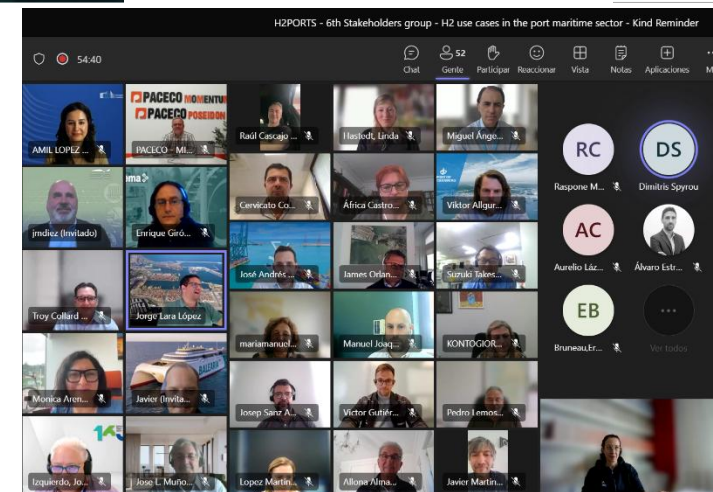

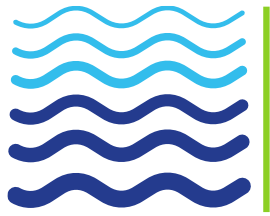

05 Communication Results



Web



Newsletters



Conferences



News

PORTSTRATEGY

INSIGHT FOR PORT EXECUTIVES

Hydrogen equipment trials

27/02/2024

Trials of a hydrogen powered reach stacker and terminal tractor are underway in the Port of Valencia, marking a double first for the operation of this type of equipment. Mike Mundy reports



LinkedIn



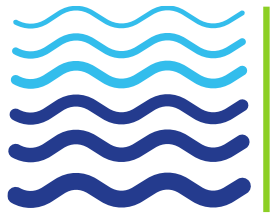

06 Conclusions



- Hydrogen technology successfully integrated into port operations
- Safe and efficient performance under real conditions. Procedures, coordination and training
- Potential reduction of emissions and pollutants on port terminals and onboard. Noise emissions very limited
- High potential for scalability and adoption in other ports

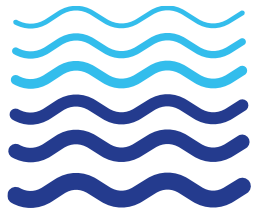

VIDEO

0:00:04 0:06:56

3 - Final Video of H2PORTS project

The logo for H2 PORTS features a stylized blue wave icon to the left of the text 'H2 PORTS'. The 'H2' is in a light green color, and 'PORTS' is in a dark blue color.

Funded by:



Partners:

